

Belt Press

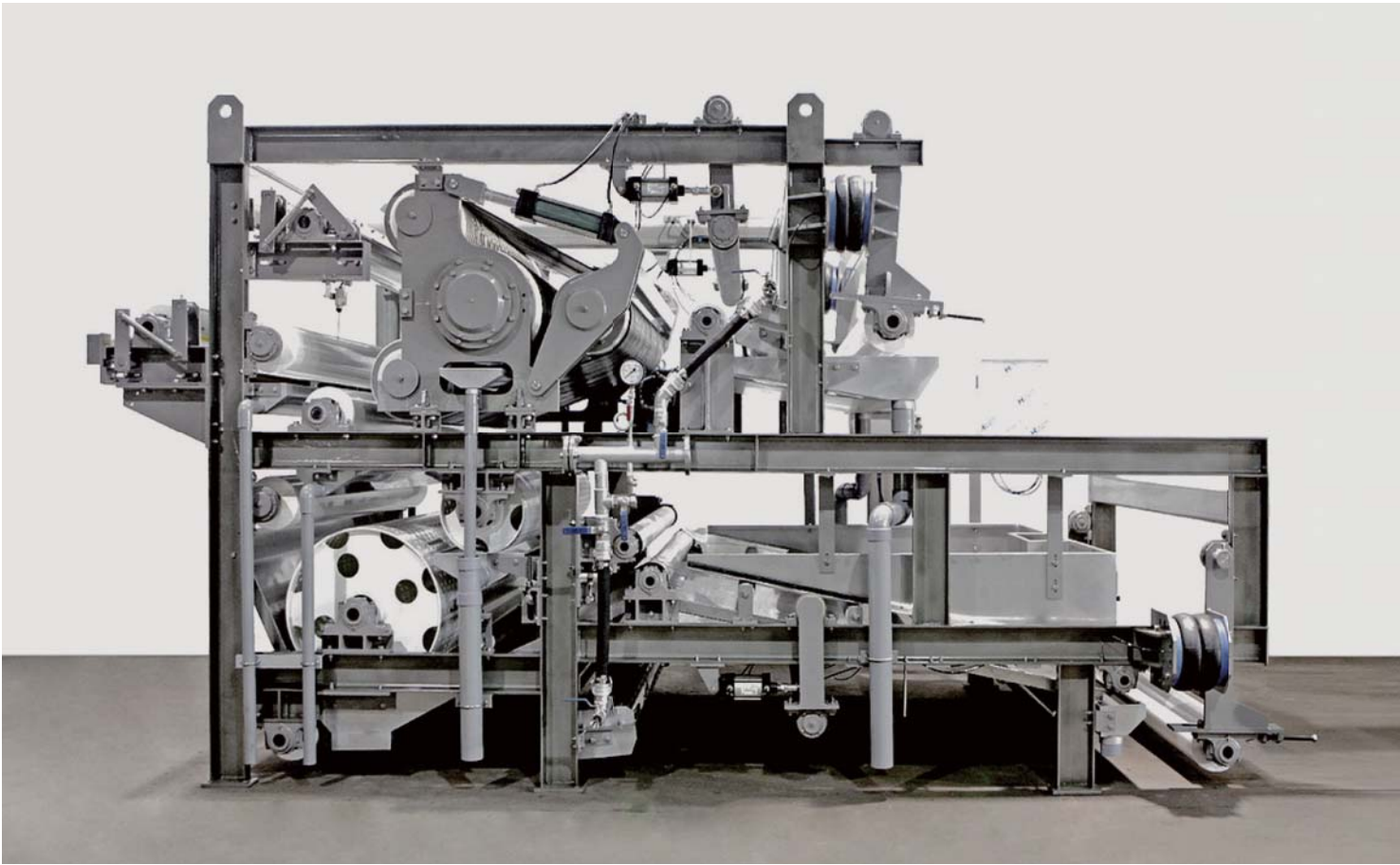

YUCHEON ENGINEERING Belt Press

After providing sludges concentrated between 2 belts(filter cloth) of top and bottom that are continuously driving, it dehydrates with multiple roller compressors and high pressure belts.

It automatically dehydrates sludges in succession of Gravity enriching section - Dehydration section - Wedge - Pressure - Compression section - High pressure section - Driving roller.

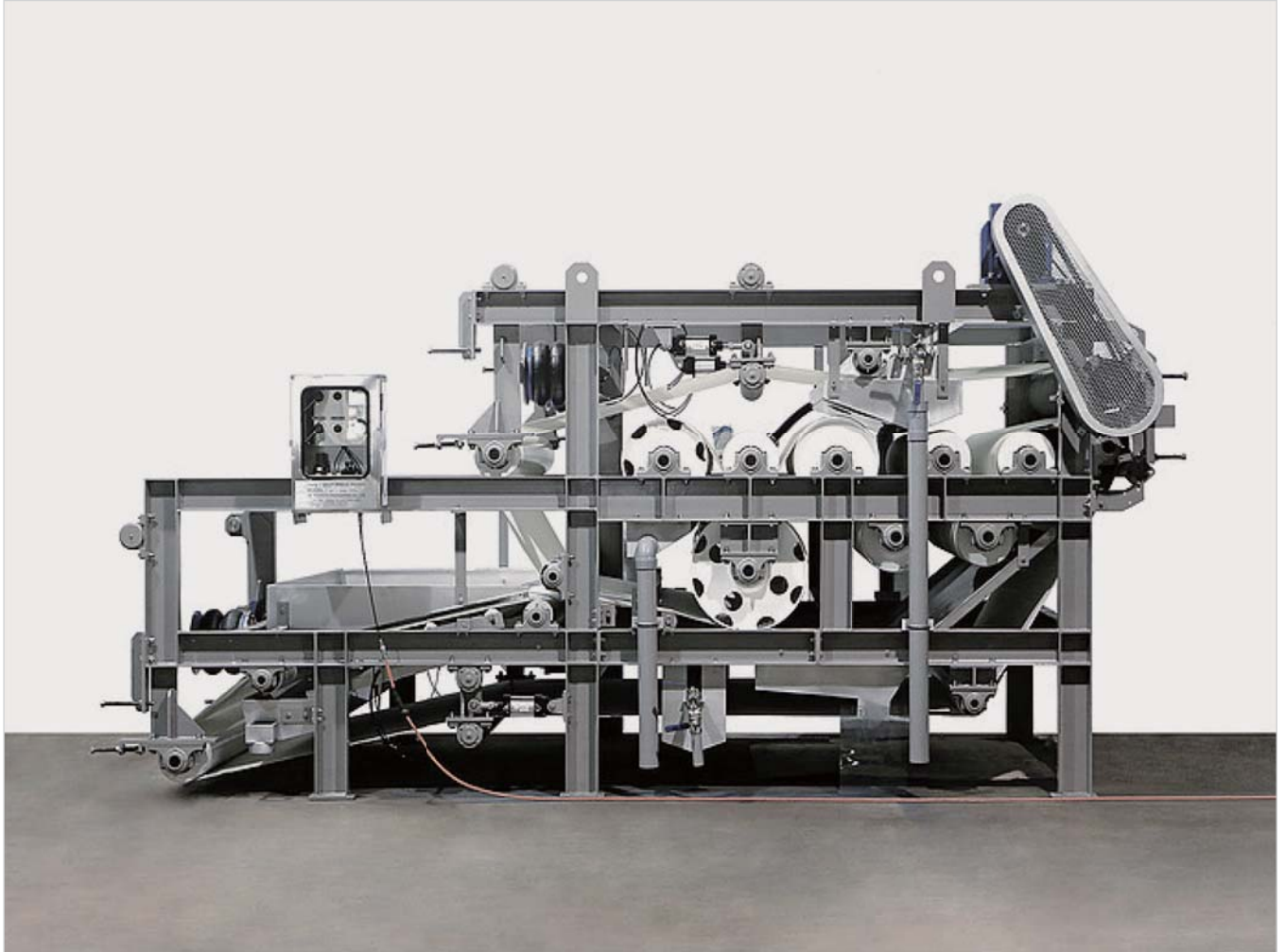

Features of Belt Press

- Driving Management: Easy operation with sludge concentration control device / Unmanned automation of PID control system.
- Frame: The optimal structure of easy maintenance.
- Main Compression Rate: Scientific roller arrangement based on the diameter inverse proportion principle. The contact surface from #1 to #6(7, 8, 9) stage is wide and long with the horizontal and vertical arrangement, and the dehydration efficiency is excellent with high pressure dehydration by hydraulic pressure.
- Dehydration Roller: 6 stages, 8 stages, 10 stages.
- Bearing Housing: The application of Oil Seal, O-Ring, Multiple Labyrinth Seal and Lip Seal to solid type housing completely protects bearings from moisture and gas.
- High Pressure Part: Hydraulic pressure is available only with air supply without using motor in hydraulic units / Equipped with the safety to protect high pressure part and other devices at overload / Consists of high pressure belt of corrosion and wear resistant NBR material, multiple hole roller with excellent dehydration efficiency, main driver roller and groove processed groove rollers.

Type of Belt Press

YUCHEON ENGINEERING provides various customized products according to customers' environments and requirements.

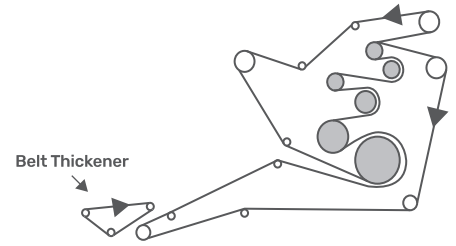

T Type

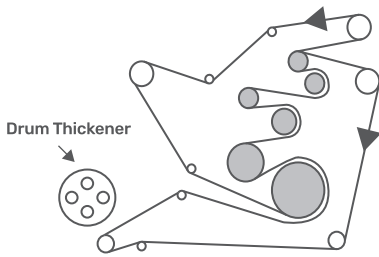

D Type

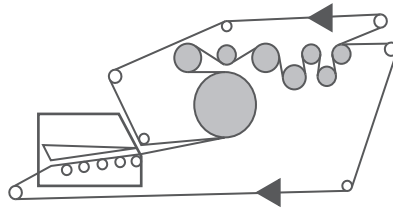

NP Type

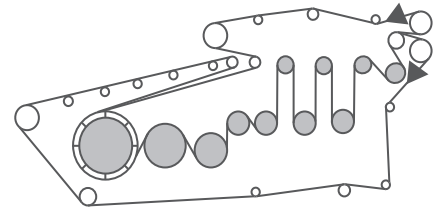

NPHS Type

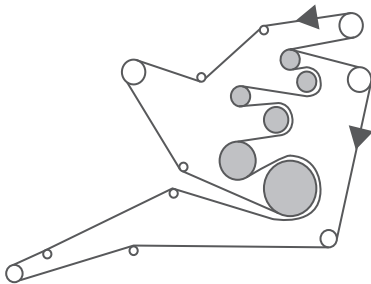

SP Type

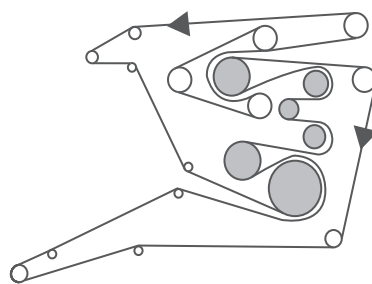

SPH Type

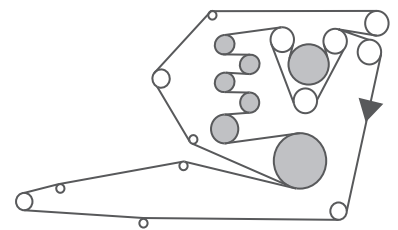

SPH(Special) Type

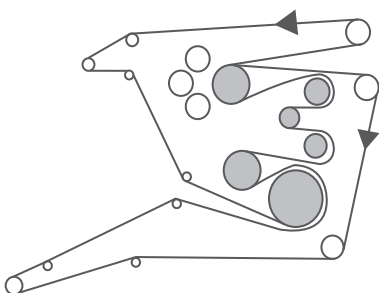

SPHS Type

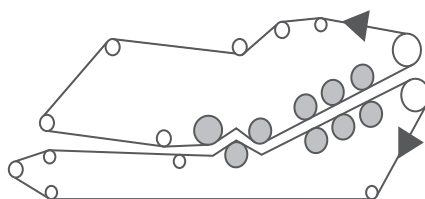

SPE Type

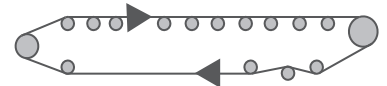

YGBT Type

Belt Press Specification

SP Type

(Standard Type Vertical Arrangement)

Pressurized dehydrator with a scientific 6 stage roller structure in the diameter inverse proportion principle.

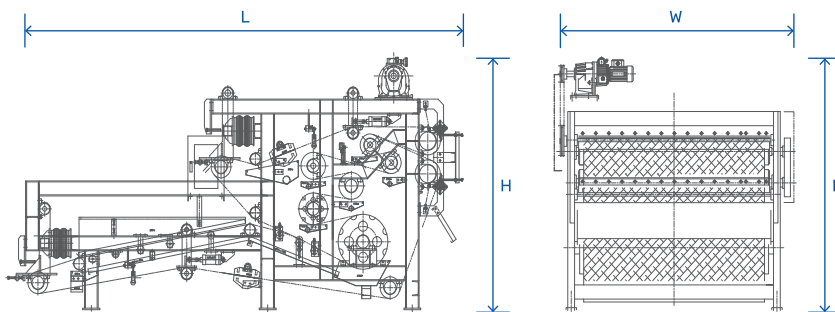

Technical Data	Power		Filter Cloth Width	Throughput	Size			Approx Weight	Height of Building for Installation
	Main Drive	Air Compressor			Length	Width	Height		
Model	KW	KW	mm	m ² /hr	mm	mm	mm	kg	mm
SP-500	0.40	0.75	500	0.5-3.0	3,150	1,015	1,970	1,800	3,500
SP-650	0.40	0.75	650	1.5-4.5	3,785	1,300	2,200	2,500	4,000
SP-1000	0.75	0.75	1,000	3.0-6.5	3,785	1,650	2,200	3,100	4,000
SP-1500	1.50	0.75	1,500	4.0-9.5	4,620	2,170	2,460	5,000	4,500
SP-2000	1.50	0.75	2,000	5.0-13.0	4,620	2,650	2,460	7,000	4,500
SP-2500	2.20	0.75	2,500	7.0-15.0	4,820	3,340	2,720	11,000	5,000
SP-3000	2.20	0.75	3,100	8.0-20.0	4,820	3,940	2,720	13,000	5,000

SPH Type

(High Pressure Type)

Pressurized dehydrator with Standard Type Vertical Arrangement + High Pressure Belt attached and hydraulic pressure applied.

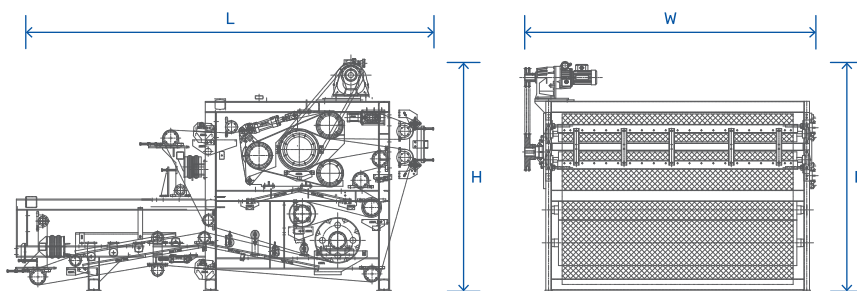

Technical Data	Power		Filter Cloth Width	Throughput	Size			Approx Weight	Height of Building for Installation
	Main Drive	Air Compressor			Length	Width	Height		
Model	KW	KW	mm	m ² /hr	mm	mm	mm	kg	mm
SPH-1000	1.50	0.75	1,000	4.0-9.5	4,500	1,580	2,825	5,000	4,500
SPH-1500	2.20	0.75	1,500	5.0-12.5	4,850	2,480	2,995	8,000	5,000
SPH-2000	2.20	0.75	2,000	6.0-16.0	4,850	2,960	2,995	11,000	5,000
SPH-2500	3.70	0.75	2,500	8.0-22.0	5,400	3,665	3,469	17,000	5,500
SPH-3000	3.70	0.75	3,100	9.0-26.0	5,400	4,165	3,469	18,000	5,500

SPHS Type

(Extra High Pressure Type)

Suitable for paper dehydration

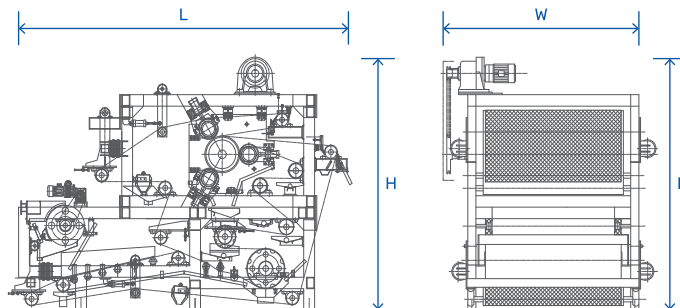

Technical Data	Power		Filter Cloth Width	Throughput	Size			Approx Weight	Height of Building for Installation
	Main Drive	Air Compressor			Length	Width	Height		
Model	KW	KW	mm	m ² /hr	mm	mm	mm	kg	mm
SPHS-1000	3.70	0.75	1,000	4.5-10.5	5,000	2,100	3,500	10,000	6,500
SPHS-1500	5.50	0.75	1,500	5.5-14.0	5,430	2,686	4,037	15,000	7,000
SPHS-2000	7.50	0.75	2,000	6.5-17.5	5,430	3,186	4,037	18,000	7,000
SPHS-2500	11.00	0.75	2,500	8.5-24.5	6,050	3,760	4,405	23,000	7,500
SPHS-3000	11.00	0.75	3,100	10.0-28.5	6,050	4,260	4,405	28,000	7,500

* The measurement is subject to change according to specifications (drawings).

NP(8 stage) Type (Standard Type Horizontal Arrangement)

Pressurized dehydrating method with a scientific 8 stage roller structure in the diameter inverse proportion principle.

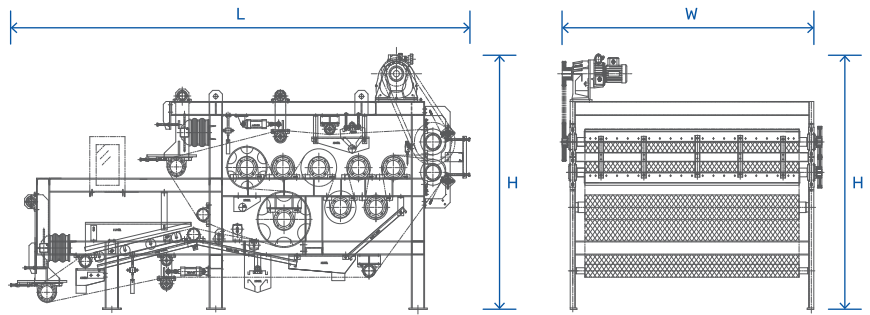

Technical Data	Power		Filter Cloth Width	Throughput	Size			Approx Weight	Height of Building for Installation
	Main Drive	Air Compressor			Length	Width	Height		
Model	KW	KW	mm	m ² /hr	mm	mm	mm	kg	mm
NP-500	0.40	0.75	500	0.5-3.0	4,620	1,080	2,310	1,950	4,000
NP-650	0.40	0.75	650	1.5-4.5	4,620	1,230	2,310	2,700	4,000
NP-1000	0.75	0.75	1,000	3.0-6.5	4,620	1,580	2,380	3,200	4,000
NP-1500	1.50	0.75	1,500	4.0-9.5	4,880	2,170	2,700	5,200	4,600
NP-2000	1.50	0.75	2,000	5.0-13.0	4,880	2,650	2,700	7,300	4,600
NP-2500	2.20	0.75	2,500	7.0-15.0	4,900	3,340	2,725	11,400	4,800
NP-3000	2.20	0.75	3,000	8.0-20.0	4,900	3,940	2,725	13,500	4,800

NPHS Type (High Pressure Type)

Pressurized dehydrator with Standard Type Horizontal Arrangement + High Pressure Belt attached and hydraulic pressure applied.

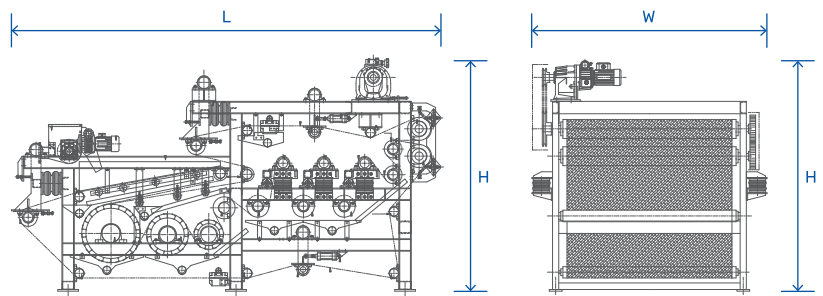

Technical Data	Power		Filter Cloth Width	Throughput	Size			Approx Weight
	Main Drive	Air Compressor			Length	Width	Height	
Model	KW	KW	mm	m ² /hr	mm	mm	mm	kg
NPHS-1000	1.50	0.75	1,000	3.0-8.0	4,070	1,330	2,446	6,000
NPHS-1500	2.20	0.75	1,500	4.0-11.0	4,995	2,370	2,750	8,000
NPHS-2000	2.20	0.75	2,000	5.0-15.0	4,995	2,850	2,814	12,000
NPHS-2500	3.70	0.75	2,500	7.0-20.0	5,307	2,945	2,970	15,000
NPHS-3000	3.70	0.75	3,000	8.0-25.0	5,130	3,545	2,963	17,000

Performance Data of High Pressure Type Belt Press

Nature of Sludge		Inlet Concentration	Polymer Concentration	Treatment Capacity	Outlet Concentration
		%	%/ton_ds	kg-ds/m/hr	%
Municipal Sludge	Mixed Sludge	2.0 - 6.0	0.3 - 0.8	150 - 300	55 - 75
	Activated Excess Sludge	1.0 - 3.0	0.5 - 1.0	120 - 280	70 - 78
Night Soil Sludge	Digested Sludge	3.0 - 6.0	0.3 - 0.6	200 - 500	55 - 70
	Activated Excess Sludge	1.0 - 3.0	0.5 - 1.0	100 - 280	72 - 80
	Activated Excess Sludge	1.0 - 2.5	0.6 - 1.0	100 - 250	70 - 80
Slaughter House Sludge	Primary+Excess Activated +Coagulate Sludge	2.0 - 4.0	0.5 - 0.8	110 - 260	70 - 80
	Mixed Sludge	1.5 - 6.0	0.3 - 0.8	100 - 300	65 - 75
Industrial Sludge	Tannery Sludge	3.0 - 5.0	0.3 - 0.8	100 - 300	65 - 77
	Dyeing Sludge	1.5 - 2.5	0.4 - 1.0	100 - 250	75 - 81
	Metal Sludge	3.0 - 5.0	0.2 - 0.6	150 - 450	50 - 65
	Gilding Sludge	1.5 - 2.5	0.2 - 0.6	100 - 300	60 - 72
	Paper Mill Sludge	2.0 - 5.0	0.2 - 0.4	150 - 600	52 - 68
	Stone Sludge	20.0 - 40.0	0.1 - 0.2	800 - 1000	20 - 35
	Food Activated Sludge	1.0 - 2.0	0.4 - 0.8	80 - 140	75 - 82
	Chemical Activated Sludge	1.0 - 3.0	0.4 - 0.8	80 - 130	75 - 82
	Marine Product Sludge	1.0 - 2.5	0.4 - 0.8	80 - 130	76 - 82
	Alcohol Sludge	2.0 - 3.0	0.5 - 1.0	110 - 180	70 - 75

Belt Press Flow Sheet

Belt Press Flow Sheet

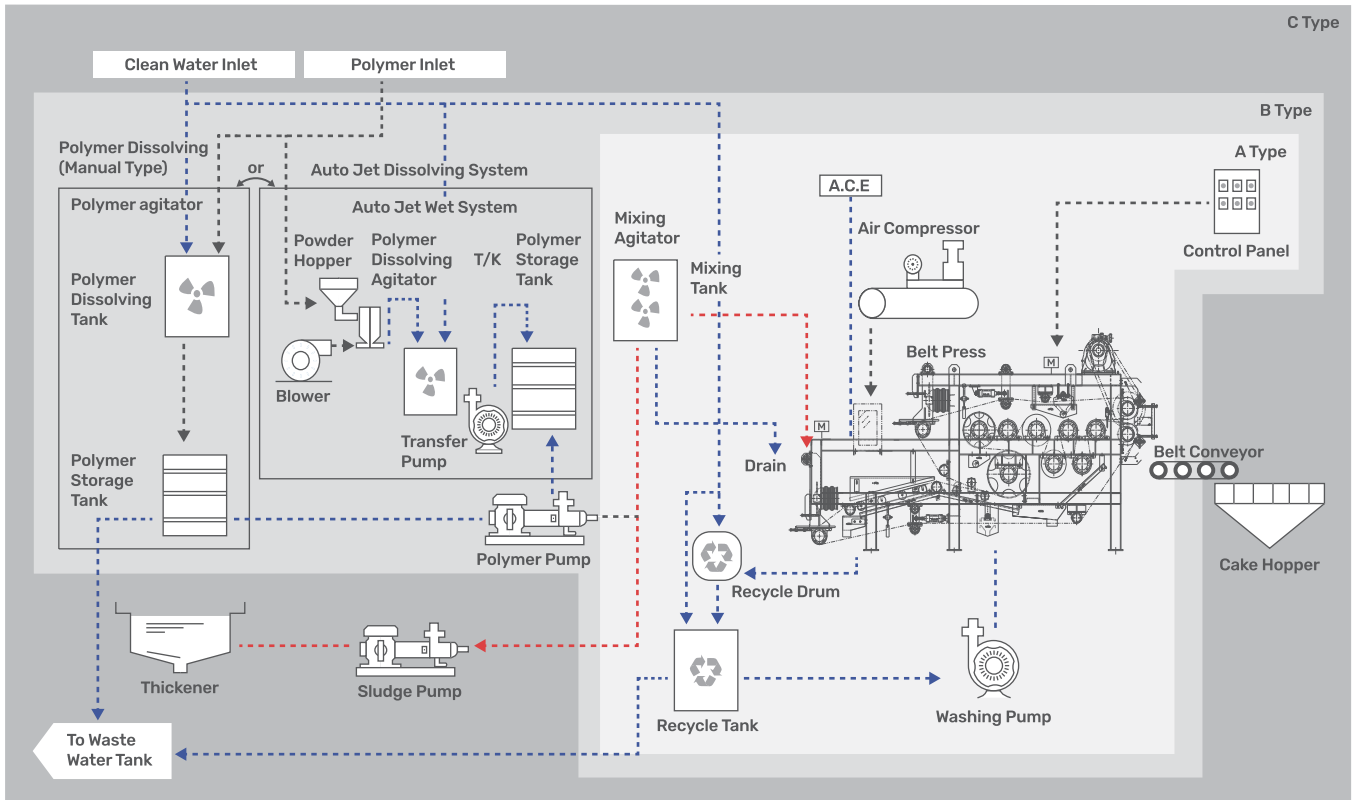

Standard Supply Scope

A Type	B Type	C Type
<ul style="list-style-type: none"> • Belt Press • Mixing tank and agitator • Standard panel • Washing pump • Air compressor • Recycle system • Walk way for mixing tank 	<ul style="list-style-type: none"> • Belt Press • Mixing tank and agitator • Standard panel • Washing pump • Air compressor • Recycle system • Walk way for mixing tank • Polymer dissolving and storage tank (manual or automatic) 	<ul style="list-style-type: none"> • Belt Press • Mixing tank and agitator • Standard panel • Washing pump • Air compressor • Recycle system • Walk way for mixing tank • Polymer dissolving and storage tank (manual or automatic) • Polymer pump • Sludge pump (mono pump) • Conveyor • A.C.E

Optional Supply Scope

- The secondary piping and wiring
- Auto feeder (For more than belt width – 2meter)
- Polymer auto-dissolving system (Auto Jet Wet)

High Efficiency

Advantages of Operation

- Automatic operation (Continuous operation for 24 hours)
- Easy operation and maintenance
- Low noise level
- High dryness with low moisture content of dewatered cake
- Closed type (Cover and fixed type with easy maintenance)
- High solid capture rate
- Worldwide reference
- Prevention of filter cloth folding according to even injection of sludge

Economy

- Low power consumption
- Low polymer consumption
- Low maintenance costs
- Saving on final disposal costs
- Saving personnel expenses with unmanned automated operation of dehydrator
- Drastic decrease of coagulant injection amount(10~20%)

Key Components and Features

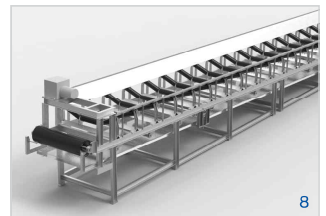
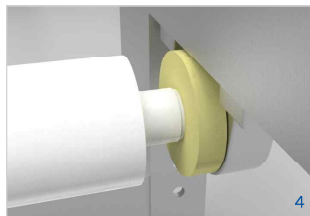
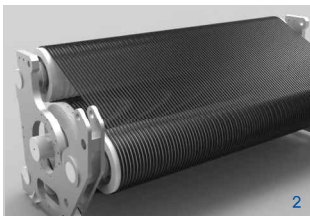
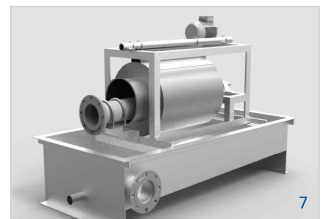
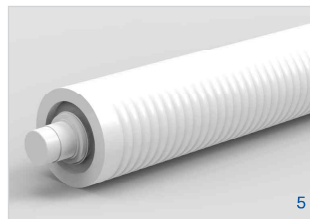
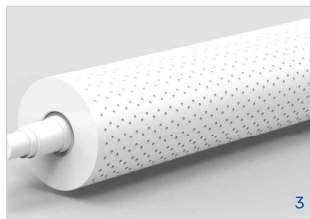
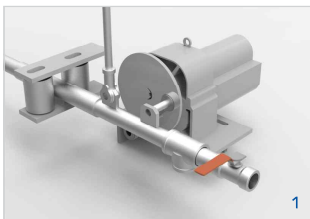

- 1** Swing Type Filter Cloth Washing System
Saving of wash water consumption / Utilizing the filtrate produced from sludge
Increase of dewatering efficiency / Prolonging the filter cloth life-span
Saving of expenses for installation(No need of high pressure pump)
- 2** 10 times strengthened high pressure dewatering zone, constructed with high pressure belt and hydraulic unit
10% reduction of dewatered cake's moisture content and 30% reduction of dewatered cake's volume

Application

- Sewage treatment
- Activated sludge
- Harbour sludge
- Sludge in food and beverage manufacturing plant
- Contaminated soil
- Dredging
- Residue from quarries
- Various industrial sludges
(Cement, Coal, Mineral, Concentrates, Copper, Zinc, Iron, Nickel, Silver, Gold Etc.)

Pilot Testing

Sludge test can be done to decide the right model of belt press and expect the best output of water content from all different types of sludge. Please send us your sludge sample if necessary as we offer sludge test service using our pilot machine at our site.

- 3** Anti-abrasion/corrosion protection, coated with thermoplastic polyamide powder(Rilsan)
- 4** 100% waterproof, multiple labyrinth seal, oil seal and O-ring (option)
- 5** Grooved roller to prevent filter cloth from overlapping&damages (option)
- 6** Wheel Brush: Automatic nozzle cleaning system
- 7** Recycle system with utilizing filtrate as washing water
- 8** Conveyor: Moving device for dewatered cake discharged from belt press into cake hopper

Address 77B-2L, Namdong Industrial Complex, 56, Namdongdong-ro 198beon-gil, Namdong-gu, Incheon, S. Korea.

Telephone +82 (0)2 2686 2576

Fax +82 (0)2 2686 2530

E-mail yucheon@yucheon.com

Website www.yucheoneng.co.kr